

Terminal Protection to IP20



Dims: to DIN 43880 W. 17.5mm

- ❑ ***NEW* 17.5mm DIN rail housing**
- ❑ **Microprocessor based**
- ❑ **True R.M.S. monitoring**
- ❑ **Monitors own supply and detects if one or more phases exceed the fixed Under or Over voltage trip levels**
- ❑ **Measures phase to phase voltages**
- ❑ **Detects incorrect phase sequence and phase loss**
- ❑ **Selectable Nominal voltages (Un) – 2 voltage versions available**
- ❑ **Fixed Under and Over voltage trip levels (±10% of selected Nominal voltage)**
- ❑ **Adjustment for Restart delay (1 – 500 seconds)**
- ❑ **1 x SPDT relay output 8A**
- ❑ **Green LED indication for supply status**
- ❑ **Red LED indication for relay status**



FUNCTION DIAGRAM

Under and Over Voltage Monitoring

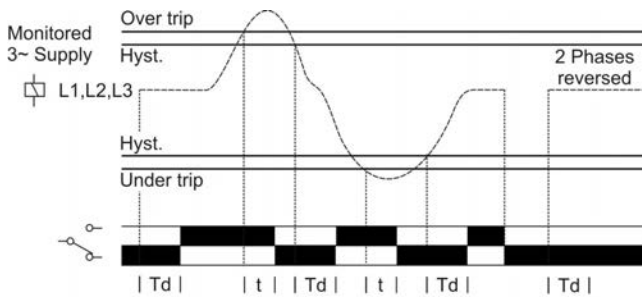

INSTALLATION AND SETTING



Installation work must be carried out by qualified personnel.

- BEFORE INSTALLATION, ISOLATE THE SUPPLY.
- Connect the unit as required. The Connection Diagram below shows a typical installation, whereby the supply to a load is being monitored by the Phase monitoring relay. If a fault should occur (i.e. fuse blowing), the relay will de-energise and assuming control of the external Contactor, de-energise the Contactor as well.

Setting the unit.

- Set the "Nominal Voltage (Un)" selector to match the voltage of the supply to be monitored.
- Set the "Restart Delay" to the desired position.

Applying power.

- Apply power and the green "Power supply" LED will illuminate. The red LED will flash for the duration that is set on the "Restart Delay" adjustment.
- After the set delay has elapsed, the relay will energise and contacts 15 and 18 will close. The red LED will now remain illuminated. Refer to the troubleshooting table if the unit fails to operate correctly.

Under / Overvoltage Fault condition.

- If the monitored supply voltage increases above the fixed over voltage or decreases below the fixed under voltage trip level, the relay will de-energise after delay "t". The red LED will extinguish when the relay de-energises.
- The relay will re-energise after the Restart Delay (Td) when the voltage either increases above the under voltage trip level plus the hysteresis or decreases below the over voltage trip level minus the hysteresis.

Troubleshooting.

The table below shows the status of the unit during/after a fault condition.

Supply fault	Green LED	Red LED	Relay
After power applied / fault cleared	On	Flashing	De-energised for set delay (Td)
Phase missing	On	Off	De-energised
Phases reversed (no delay)	Flashing	Off	De-energised
Under or Over Voltage condition (during delay "t")	On	On for delay (t)	Energised for delay (t)
Under or Over Voltage condition (after delay "t")	On	Off	De-energised
Phase below 70% of Un (fixed under trip level [2])	On	Off	De-energised

TECHNICAL SPECIFICATION

Selectable nominal voltages	LV version: 200, 208, 220, 230, 240V AC	
Un* (L1, L2, L3):	Std version: 380 ³ , 400 ³ , 415 ³ , 440 ³ , 460V ³ AC	
Frequency range:	48 – 63Hz	
Supply variation limits:	LV: 146 – 286V AC Std: 266 – 540V AC	
Overvoltage category:	III (IEC 60664)	
Rated impulse withstand voltage:	1 ⁴ kV (1.2/50μs) IEC 60664	
Power consumption (max.):	8VA	
Monitoring mode:	Under and Over voltage	
Trip levels:	Under: 90% of Un (fixed) Over: 110% of Un (fixed)	
Trip voltages for select Nominal:		
Nominal	Under	Over
200V:	180V	220V
208V:	187V	229V
220V:	198V	242V
230V:	207V	253V
240V:	216V	264V
380V:	342V	418V
400V:	360V	440V
415V:	374V	457V
440V:	396V	484V
460V:	414V	506V
Trip level accuracy:	± 2%	
Hysteresis:	≈ 2% of trip level (factory set)	
Repeat accuracy:	± 0.5% at constant conditions	
Immunity from micro power cuts:	<50mS	
Response time:	≈ 50mS	
Time delay (t):	4 sec. (± 5%) <i>Note: actual delay (t) = time delay + response time</i>	
Restart delay (Td):	1 – 500 sec.	
Setting accuracy:	± 3%	
Delay from Phase loss (tr):	≈ 1 sec. (worst case = tr x 2)	
Power on indication:	Green LED	
Relay status indication:	Red LED	
Ambient temp:	-20 to +70°C (Supply voltage not to exceed 264V AC (LV version) or 480V AC (Std version). If voltage above this, derate max. ambient temperature to +60°C)	
Relative humidity:	+95%	
Output (15, 16, 18):	SPDT relay	
Output rating:	AC1 250V 8A (2000VA) AC15 250V 5A (no), 3A (nc) DC1 25V 8A (200W)	
Electrical life:	≥ 150,000 ops at rated load	
Dielectric voltage:	2kV AC (rms) IEC 60947-1	
Rated impulse withstand voltage:	4kV (1.2/50μs) IEC 60664	
Housing:	Orange flame retardant UL94	
Weight:	75g	
Mounting option:	On to 35mm symmetric DIN rail to BS EN 60715 or direct surface mounting via 2 x M3.5 or 4BA screws using the black clips provided on the rear of the unit.	
Terminal conductor size:	≤ 2 x 2.5mm ² solid or strande ⁴	
Approvals:	Conforms to IEC. <small>IND. CONT. EQ. E111187</small> CE, and RoHS Compliant. EMC: Immunity: EN 61000-6-2 (EN 61000-4-3 15V/m 80MHz - 2.7GHz). Emissions: FN 61000-6-4	

* Please state voltage variant when ordering

CONNECTION DIAGRAM

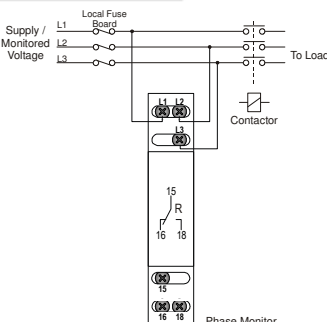

SETTING DETAILS

1. Power supply status (Green) LED
2. Relay output / Timing status (Red) LED
3. "Nominal Voltage (Un)" selector
4. "Restart Delay" adjustment^A

^Ascale digits to be multiplied by 100 for actual delay (i.e. 2 x 100 = 200 seconds)

Front layout example shown for the 380 > 460V version.

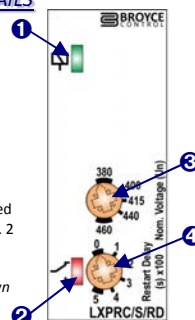

DIMENSIONS

