

**Y**  
SERIES

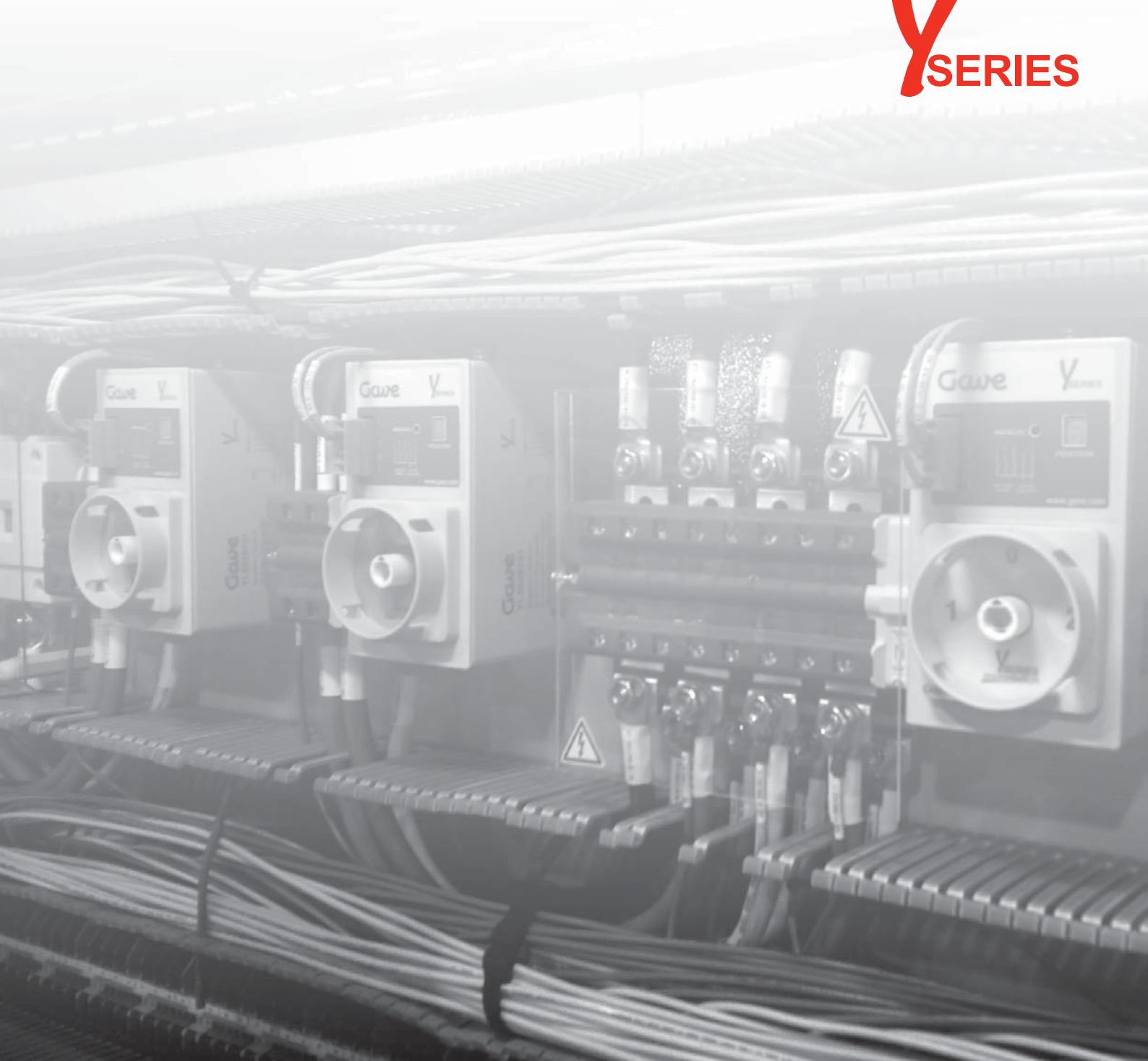

## Motorised changeover and Automatic Transfer Switches (ATS)

**Gawe**  
low voltage electrical material





## Contents

Introduction	4
Motorised switches	6
Motorised changeover switches	12
Overlapping motorised changeover switches	13
Multiple ways motorised changeover switches	14
Multiple sources motorised changeover switches	15
Phase selector motorised changeover switches	16
Motorised switches	17
Automatic transfer switch (ATS)	18
ATS with signalling	23
ATS with measuring	24
ATS with emergency function	25
ATS with controller	26
ATS with By-pass	28
Other products	31



## Company

Gawe Electro is an international manufacturer of electrical control products and solutions with an extensive professional record since it was founded in 1944. It has developed technical capabilities on the low voltage breaking, control and protection fields acquiring strong reputation on its control equipment solutions.

## Innovation

Innovative thinking is our philosophy. We create better more effective products and processes applying new ideas that benefit from our longstanding experience. A dedicated engineering team boosting your competitiveness.



*Specialist in electrical  
control technology*

## Quality & Service Commitment

Gave Electro follows a total quality management (TQM) system as an integrative philosophy of management for continuously improving the quality of products and processes. This system functions on the premise that the quality of products and processes is the responsibility of everyone who is involved with the creation or consumption of the products and involves management, workforce, suppliers, and even customers, in order to meet or exceed customer expectations.

Constant rigorous product testing is undertaken during all production process in order to guarantee specs accuracy and product reliability.

Testing capabilities include:

- Electrical and mechanical endurance
- Ingress protection (IP) testing
- EMC reinforced testing
- Optical and thermal parts analysis
- Dielectric testing
- Flammability and ignitability (glow wire test)

We commit to service our customer by providing support in planning, installation, training, trouble shooting, maintenance, upgrading, and disposal of a product.



«Smart solution on your *remote operated changeover* applications combining performant *switching* technology with *functional* installation requirements»



## Motorised switches



Gawe Y Series motorised changeover switches have been designed to perform distant changeover operations.

They secure electromechanical reliability in all sort of applications: transfer supply-generator with or without break, main switch, multiple source switch, by-pass, ...

Modern industrial and service companies require standby power systems in order to avoid high costs

related to supply breakdowns. An increasing number of countries are approving new legislation involving backup power sources on business and administration installations open to public service. Rising residential comfort requirements are also demanding for systems that guarantee power supply continuity. Therefore an increasing number of installations demand source changeover products covering this function.

## Product overview

### Standard Motorised changeover switches

Easy connection, input sources on top and load output on bottom.



40-63A AC22



63-100-125A



160-200-250A

### Motorised switches



40-250A

### Special Motorised changeover switches



*Overlapping motorised changeover switches*  
63-250A



*Multiple ways mot. changeover switches*  
40-250A



*Multiple sources mot. changeover switches*  
63-250A



*Phase selector mot. changeover switches*  
40-250A

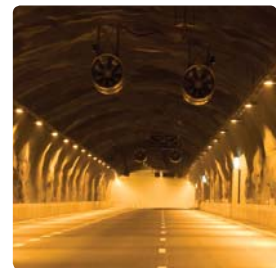

Motorised changeover switches are an ideal response to the practical requirements of remote changeover operations. Industrial and commercial low voltage distribution systems install motorised changeover switches that additional to remote changeover operation also offer local operation adding safety on the installation on emergency circumstances or maintenance conditions.

## Applications

- Automatic transfer supplies.
- System automation.
- Condominium power supplies.
- Battery supply systems.
- Emergency supplies.
- IT power supply systems.
- Ventilation and heating systems.

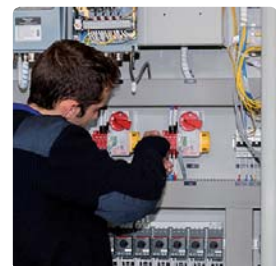



# Y SERIES

## Motorised switches

Gawe Y series motorised changeover switches have been designed to perform remote changeover operations.

According to standards

- IEC 60947-3
- IEC 60947-6-1
- IEC 61000

General characteristics

- Switch element:
  - Load break switch at 90°.
  - Silver alloy contacts.
  - Easy terminal accessibility.
  - Connection on protected cable clamps.
  - Body cells on self-extinguishing GRP.
- Driving element:
  - Mechanical operation runned by DC electric motor.
  - Motor operation electronically controlled.
- Control element:
  - Electronic control by magnetic position recognition.

- Operation counter.
- Abnormal voltage supply protection.
- Complete set:
  - Integrated auxiliary contacts, shaft linked to the changeover unit.
  - Internal common link integrated in contact chamber.
  - One input signal available for each changeover switch mechanical position.
  - Digital display allows reading out changeover position.
  - Plug-in terminal block for signal connection.
  - Power supplies 12, 24 and 48V DC, and 80 to 220V AC.
  - Compact dimensions.
  - Rear panel fixing.
  - Endurance: > 30.000 on load operations and 50.000 mechanical operations.
  - Manual operation overrides automatic operation.

### → *Changeover switching*

Performant switching technology providing safety isolation, outstanding electrical endurance and high make/break capacity. Built-in internal link integrates two circuits.

### → *Installation*

Easy cable connection on base mounted product. No installation difficulties as common link, mechanical and electrical interlock are internally built-in. Saving time and start-up problems.

### → *Control*

Your equipment is run by electronic control that commands motorised operations and informs on operation mode and position status. In case of multiple orders, switching priorities are established by program.

### → *Safety*

Local operation guarantees safe disconnection under all circumstances.



## Characteristics

**Control terminals**  
Simple push-in terminals controlling the switch.

**Operations counter**  
3 shaft pushes and blinking digit will indicate number of operations.

**Visual indication**  
Digital position readout. Manual operation red LED lights on.

**Manual operation**  
Possibility to perform manual backup operation.

**Padlockable handle**  
Up to 4 padlocks on maintenance conditions.

**Protection Screen**  
Supplied from origin on cable lug connection units.

**Auxiliary contacts**  
Operated with the same shaft as power contacts.

**Compact motor block**  
Protected against unstable power supply.

# Dimensions

## 40A - 63A AC22

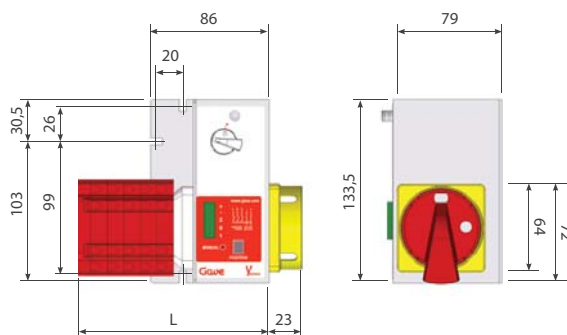

Scheme	L
561/541	117
562/542	127
563/543	137
568	177
569	187
392	157
393	177
580	127

## 63A - 100A - 125A

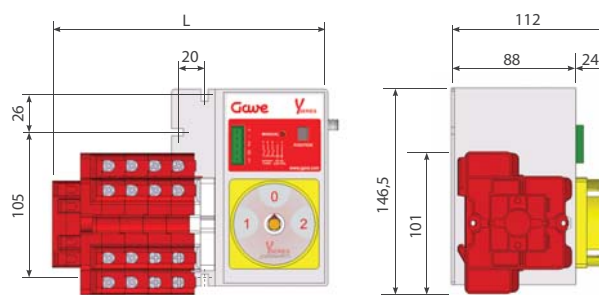

Scheme	L
561/541	162
562/542	178,5
563/543	195
568	215,5
569	232
392	192,5
393	225,5
611	172

## 160A - 200A - 250A

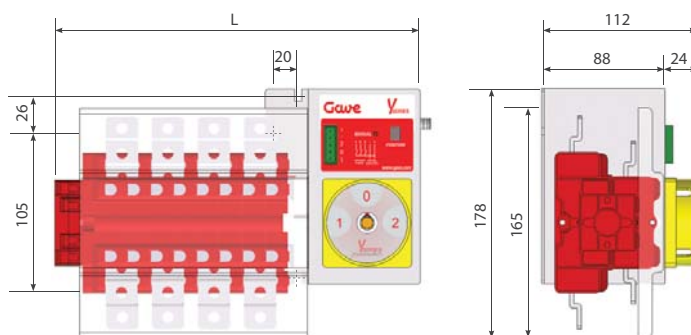

Scheme	L
561/541	199
562/542	232
563/543	265
568	397
569	430
392	341
393	374
611	209

### Rotary cam technology: Unbeatable electrical endurance

IEC 60947-6-1 establish an electrical endurance of 1500 operations as standard category and 6000 operations in A type category. However on remote areas where using generators as PRP we can get up to 1000 transfer operations per year and therefore standard electrical endurance is clearly insufficient to real field

applications. By design Cam Switching technology is made for constant operations and proves an ideal solution to this field operation. Where lever or block technologies show their limits, motorised changeover switches based on cam technology are the right technology that has been tested for 30.000 electrical operations.

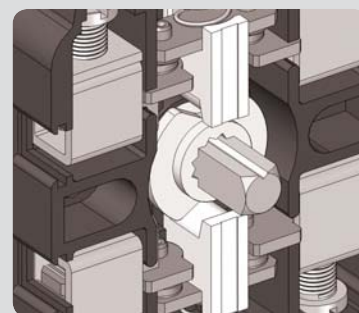

## Reference system

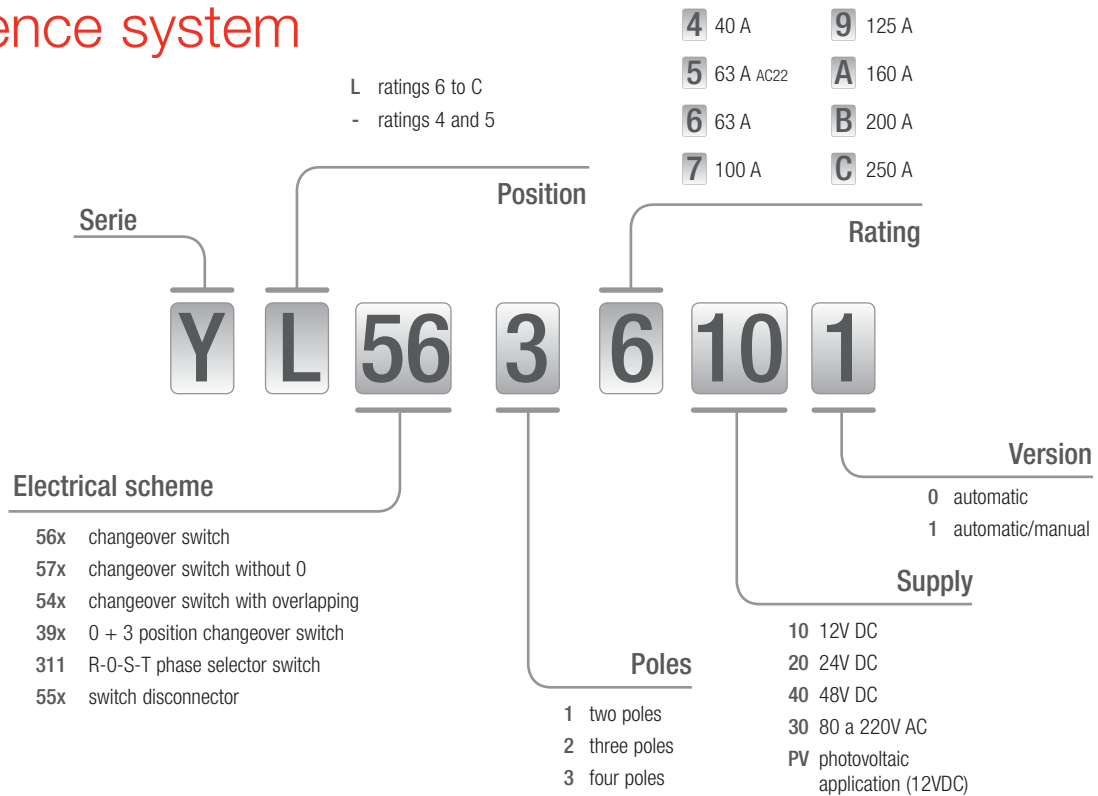

## Technical data

		40A	63A AC22	63A	100A	125A	160A	200A	250A	
Rated voltage/frequency	V/Hz									
Thermal rating	I <sub>th</sub> (A)	50	70	70	100	125	160	200	250	
Operational rating	I <sub>e</sub> (A)	40	63	63	100	125	160	200	250	
AC-21	400V AC	kW	28	44	44	69	87	111	139	173
AC-22	400V AC	kW	22	35	-	-	-	-	-	-
AC-23	400V AC	kW	18,5	-	37	45	55	60	75	90
Peak consumption	A	2	2	2,5	2,5	2,5	2,5	2,5	2,5	
Nominal consumption	mA	40	40	40	40	40	40	40	40	
Weight	gr	1.200	1.200	2.250	2.250	2.250	2.850	2.850	2.850	
Supply voltage	V DC									
Wire section										
	stranded mm <sup>2</sup>	6-25	6-25	16-50	16-50	16-50	70	95	120	
	flexible mm <sup>2</sup>	6-16	6-16	16-50	16-50	16-50	70	95	120	
Tightening torque	Nm	2	3,5	3,5	3,5	3,5	6	6	6	
Connection screws		M5	M8	M8	M8	M8	M8	M8	M8	
Terminal										

# Motorised changeover switches

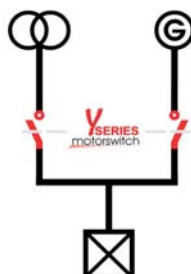

## Function

Motorised changeover switches are aimed to perform remote or local on load changeover operations. They also offer disconnection position guaranteeing circuit safety isolation. Actuator can be locked at position 0 during maintenance operations.

## Characteristics

- Compact size, small footprint.
- Internal bridges.
- Electronic position display with operation counter.
- Very low consumption.
- Integrated auxiliary contacts.

## References



### From 40 to 63A (AC22)

A	2 Poles		3 Poles		4 Poles	
	12V DC	230V AC	12V DC	230V AC	12V DC	230V AC
40	Y-5614101	Y-5614301	Y-5624101	Y-5624301	Y-5634101	Y-5634301
63 AC22	Y-5615101	Y-5615301	Y-5625101	Y-5625301	Y-5635101	Y-5635301



### From 63 to 125A

A	2 Poles		3 Poles		4 Poles	
	12V DC	230V AC	12V DC	230V AC	12V DC	230V AC
63	YL5616101	YL5616301	YL5626101	YL5626301	YL5636101	YL5636301
100	YL5617101	YL5617301	YL5627101	YL5627301	YL5637101	YL5637301
125	YL5619101	YL5619301	YL5629101	YL5629301	YL5639101	YL5639301



### From 160 to 250A

A	2 Poles		3 Poles		4 Poles	
	12V DC	230V AC	12V DC	230V AC	12V DC	230V AC
160	YL561A101	YL561A301	YL562A101	YL562A301	YL563A101	YL563A301
200	YL561B101	YL561B301	YL562B101	YL562B301	YL563B101	YL563B301
250	YL561C101	YL561C301	YL562C101	YL562C301	YL563C101	YL563C301

## Overlapping motorised changeover switches



### Function

Overlapping motorised changeover switches perform on load switching operations between two independent sources without electrical break between both positions thus guaranteeing power supply continuity.

Two incoming supplies are integrated in a single unit maneuvered with remote electric control or local manual operation.

### Characteristics

- Integrated mechanical and electrical interlock.
- Low consumption.
- Operation counter.
- No break position.
- No circuit isolation.

### Power batteries applications

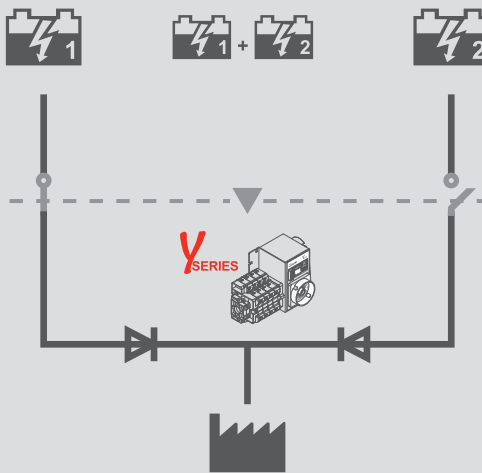

Motorised changeover switches are able to meet particular requirements related to supply systems based on power batteries.

These systems present particular challenges related to direct current loads and regular switching operations.

Standard Y Series are able to perform on load operations on battery systems up to 48Vdc. Above this voltage dedicated solutions are also available.

Cam technology is the best way to overcome difficulties related to mechanical and electrical endurance on applications with a large number of on load operations. Construction flexibility also permit to mount 2 pole products that present compact size also meaning cost savings.

### References

A	2 Poles		3 Poles		4 Poles	
	12V DC	230V AC	12V DC	230V AC	12V DC	230V AC
63	YL5416101	YL5416301	YL5426101	YL5426301	YL5436101	YL5436301
100	YL5417101	YL5417301	YL5427101	YL5427301	YL5437101	YL5437301
125	YL5419101	YL5419301	YL5429101	YL5429301	YL5439101	YL5439301
160	YL541A101	YL541A301	YL542A101	YL542A301	YL543A101	YL543A301
200	YL541B101	YL541B301	YL542B101	YL542B301	YL543B101	YL543B301
250	YL541C101	YL541C301	YL542C101	YL542C301	YL543C101	YL543C301



# Multiple ways motorised changeover switches

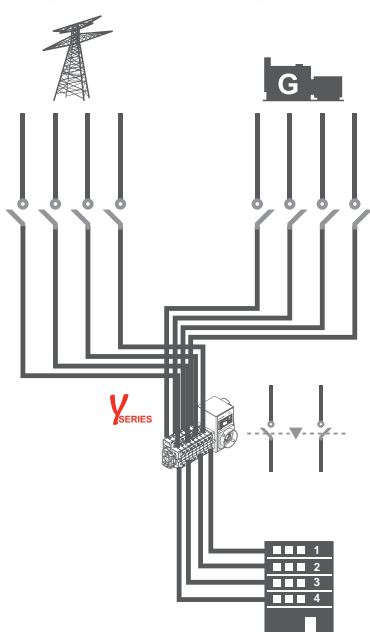

568 Ph + N 4 Apartments  
569 3Ph 3 Apartments

## Function

Gave multiple ways motorised changeover switches are aimed to perform remote or local changeover operations in multiple double or triple pole lines by using a single actuator. They are also able to fulfill circuit safe isolation when operating as a switch disconnecter.

## Characteristics

- 4 Way double pole or 3 Way triple pole.
- 40A up to 250A.
- Up to 60% space saving.
- Cost effective.

## Applications

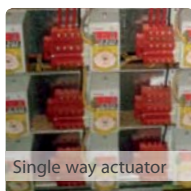

Single way actuator



Multiple ways actuator

### ¿Centralised actuator or single way actuator on distribution boards?

When designing incoming/outgoing distribution boards on residential installations the question about using individually dedicated changeovers for each outgoing load or using multiple ways changeovers will necessarily rise. Three main elements (control, space and cost) will determine your selection.

If we intend to maximise control on each outgoing supply we must use individual actuator motorised changeover for each output, this will avoid one household defective conditions or maintenance operations interfering in other household lines. However this solution does require large space allocation and carries significant cost increases, therefore on those installations where these criteria are relevant the multiple way changeovers are the right solution.

## References

Description	A	Ph+N 4 Ways Changeover		3Ph 3 Ways Changeover	
		12V DC	230V AC	12V DC	230V AC
Multi Ways Chang.	40	Y-5684101	Y-5684301	Y-5694101	Y-5694301
Multi Ways Chang.	63 AC22	Y-5685101	Y-5685301	Y-5695101	Y-5695301
Multi Ways Chang.	63	YL5686101	YL5686301	YL5696101	YL5696301
Multi Ways Chang.	100	YL5687101	YL5687301	YL5697101	YL5697301
Multi Ways Chang.	125	YL5689101	YL5689301	YL5699101	YL5699301
Multi Ways Chang.	160			YL569A101	YL569A301
Multi Ways Chang.	200			YL569B101	YL569B301
Multi Ways Chang.	250			YL569C101	YL569C301

## Multiple sources motorised changeover switches

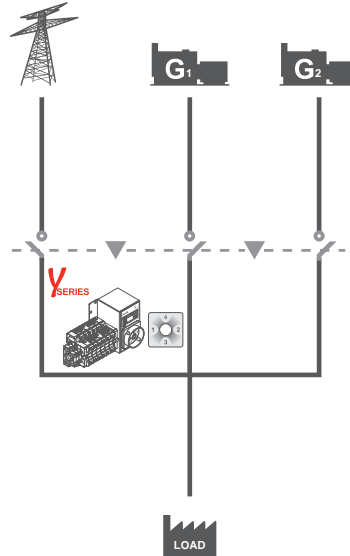

### Function

Multiple sources motorised changeover switches perform on load switching operations between three independent sources. All circuits are integrated in a single unit manoeuvred with remote electric control or local manual operation.

### Characteristics

- Integrated mechanical and electrical interlock.
- Low consumption.
- Operation counter.
- Compact size (up to 60% space saving).

### Hybrid

We can use standard multisource changeover switches on those installations where renewable source energy has been converted to AC current. Installations switching directly on DC currents require dedicated product solutions.

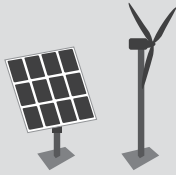

### Highlights



**Reliable interlock**  
Integrated electrical and mechanical interlock.



**Four position changeover switch**  
All in/out lines operated with a single actuator.



**Integrated bridges**  
Internal and external bridges mounted from origin.

### References

Description	A	3 Poles		4 Poles	
		12V DC	230V AC	12V DC	230V AC
0+3 position/sources	63	YL3926101	YL3926301	YL3936101	YL3936301
0+3 position/sources	100	YL3927101	YL3927301	YL3937101	YL3937301
0+3 position/sources	125	YL3929101	YL3929301	YL3939101	YL3939301
0+3 position/sources	160	YL392A101	YL392A301	YL393A101	YL393A301
0+3 position/sources	200	YL392B101	YL392B301	YL393B101	YL393B301
0+3 position/sources	250	YL392C101	YL392C301	YL393C101	YL393C301

# Phase selector motorised changeover switches

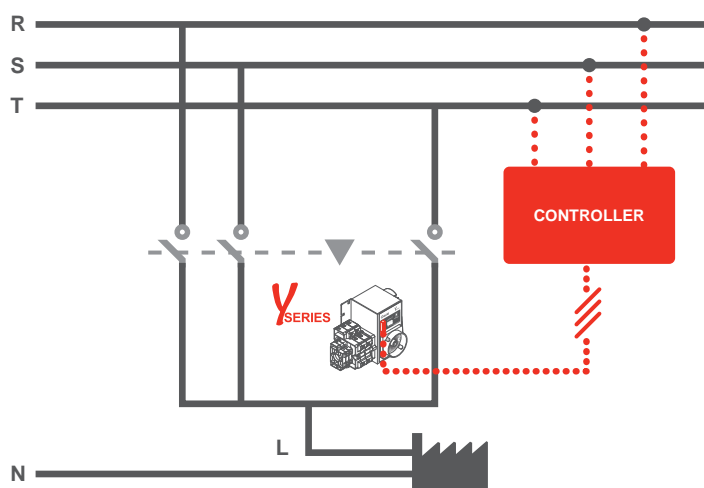

## Function

Phase motorised changeover switches perform automatic phase selection operations in order to maintain power supply continuity on single phase loads. Local manual selection is also possible. Disconnection function and circuit isolation are also featured.

## Characteristics

- Integrated mechanical and electrical interlock.
- Disconnection position.
- Integrated auxiliary contacts.
- Compact size (up to 60% space saving).

## Highlights

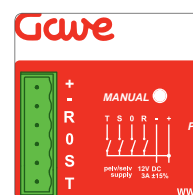

**Reliable interlock**  
Integrated electrical and mechanical interlock.

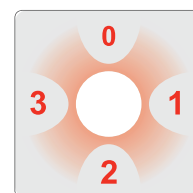

**Mechanical output phase indication**  
Automatic or manual output line selection.

## References

Description	A	Supply voltage	
		12V DC	230V AC
R-S-T phase selector motorised changeover	40	Y-5804101	Y-5804301
R-S-T phase selector motorised changeover	63 AC22	Y-5805101	Y-5805301
R-0-S-T phase selector motorised changeover	63	YL6116101	YL6116301
R-0-S-T phase selector motorised changeover	100	YL6117101	YL6117301
R-0-S-T phase selector motorised changeover	125	YL6119101	YL6119301
R-0-S-T phase selector motorised changeover	160	YL611A101	YL611A301
R-0-S-T phase selector motorised changeover	200	YL611B101	YL611B301
R-0-S-T phase selector motorised changeover	250	YL611C101	YL611C301

References 580 do not include 0 position.

## Motorised switches



**Y**  
SERIES  
motorswitch



### Function

Motorised switch disconnectors are intended to conduct remote make/break operations managed by electric control. They also offer local manual operation with padlockable handle providing circuit safe isolation during maintenance activities.

### Characteristics

- Integrated auxiliary contacts.
- Standard 3 or 4Poles. 6 and 8 P available.
- Operation counter.

### References



#### From 40 to 63A (AC22)

Description	A	3 Poles		4 Poles	
		12V DC	230V AC	12V DC	230V AC
Motorised switch	40	Y-5524101	Y-5524301	Y-5534101	Y-5534301
Motorised switch	63 AC22	Y-5525101	Y-5525301	Y-5535101	Y-5535301



#### From 63 to 125A

Description	A	3 Poles		4 Poles	
		12V DC	230V AC	12V DC	230V AC
Motorised switch	63	YL5526101	YL5526301	YL5536101	YL5536301
Motorised switch	100	YL5527101	YL5527301	YL5537101	YL5537301
Motorised switch	125	YL5529101	YL5529301	YL5539101	YL5539301



#### From 160 to 250A

Description	A	3 Poles		4 Poles	
		12V DC	230V AC	12V DC	230V AC
Motorised switch	160	YL552A101	YL552A301	YL553A101	YL553A301
Motorised switch	200	YL552B101	YL552B301	YL553B101	YL553B301
Motorised switch	250	YL552C101	YL552C301	YL553C101	YL553C301

### Dimensions

#### 63A - 100A - 125A

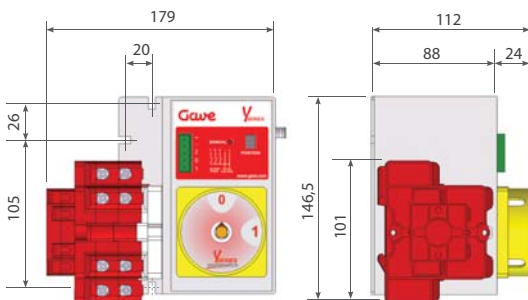

#### 160A - 200A - 250A

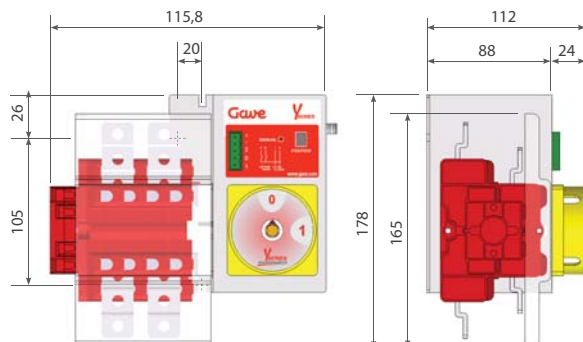

«A comprehensive range of power transfer units integrating *on load motorised changeover* and user friendly *control logic* reassuring your electrical needs.»



## Y SERIES

### Automatic transfer switch (ATS)

Strong competition has made industries, commercial and service companies increasingly dependent on power supply. Preventing consequences of power failure has become a critical element for customer service and business profitability.

Generator and auxiliary power supply systems have become

common place on modern installations from small business to large scale facilities.

A comprehensive range of Automatic Transfer Switches has been developed by Gawe based on his extensive on the field experience. Design has been done considering installation requirements and user real needs.

Gawe Yseries motorised changeover switches are the core of automatic transfer units offering state of the art electromechanical integration within an extraordinary compact size. They have been designed to perform remote switching operations while also offering local manual actuation including circuit disconnection and safe isolation.



## Product overview

### Automatic Transfer Switch Units



*ATS + Measuring  
63-250A*



*ATS  
40-250A*



*ATS + Emergency  
40-250A*

### Special products



*Special ATS*

### Compact ATS with controller



*ATS + controller  
63-250A*

### Automatic Transfers with By-pass



*ATS + By-pass  
Single line  
63-250A*



*ATS + By-pass  
Double line  
63-250A*

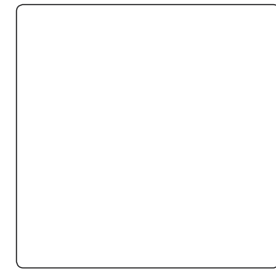

ATS based on control relays logic feature easy setup characteristics and are specially adequate on residential and commercial applications. Additional demands such as output measurement or emergency function are also available. ATS using dedicated controllers are specially compact and adequate for industrial applications. By-pass solutions are also available as standard.

## Applications

- Residential and condominiums.
- Commercial buildings.
- Telecom towers.
- Sport arenas.
- Theatres and auditoriums.
- IT power supply systems.
- Emergency systems.
- Ventilation and heating systems.

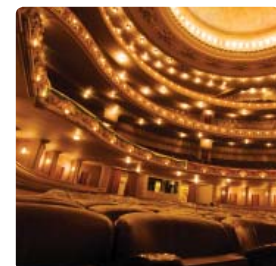

# ATS

## Automatic Transfer Switches

Gave ATS transfer switches have been designed to perform reliable load transfer operations.

According to standards

- IEC 60947-3
- IEC 60947-6-1
- IEC 61000

General characteristics

- **Motorised changeover**
  - 2 And 4 pole changeovers.
  - Ratings from 40A to 250A.
  - Local manual emergency operation.
  - Clutch mechanism detaches

- manual switching operation from motorised mechanism.
- Local padlockable handle for maintenance operations.
- Mechanical and electrical 0 position.
- **Automatic transfer (relay control):**
  - Phase presence and sequence control.
  - Voltage monitoring thresholds adjustable.
  - Operating cycles timer programmable.
  - Changeover power relays with 3 positions. Manual button for test operations.

- **Automatic transfer (controller unit):**
  - Controls up to 18 parameters (phase, voltage, frequency, time delays, transfer sequence, reset trials,..).
  - Automatic/manual modes (key).
- **Control set:**
  - Electronics fuse protected.
  - Electronics protected against surge overvoltage (optional on basic models).
  - Enduring power supplies protected against output shortcircuit.

## System reference

- CA Enclosed automatic transfer switch
- PL Open automatic transfer switch
- CT Automatic transfer switch with controller

- |                      |                  |                  |
|----------------------|------------------|------------------|
| <b>004</b> 40 A      | <b>010</b> 100 A | <b>020</b> 200 A |
| <b>005</b> 63 A AC22 | <b>012</b> 125 A | <b>025</b> 250 A |
| <b>006</b> 63 A      | <b>016</b> 160 A |                  |

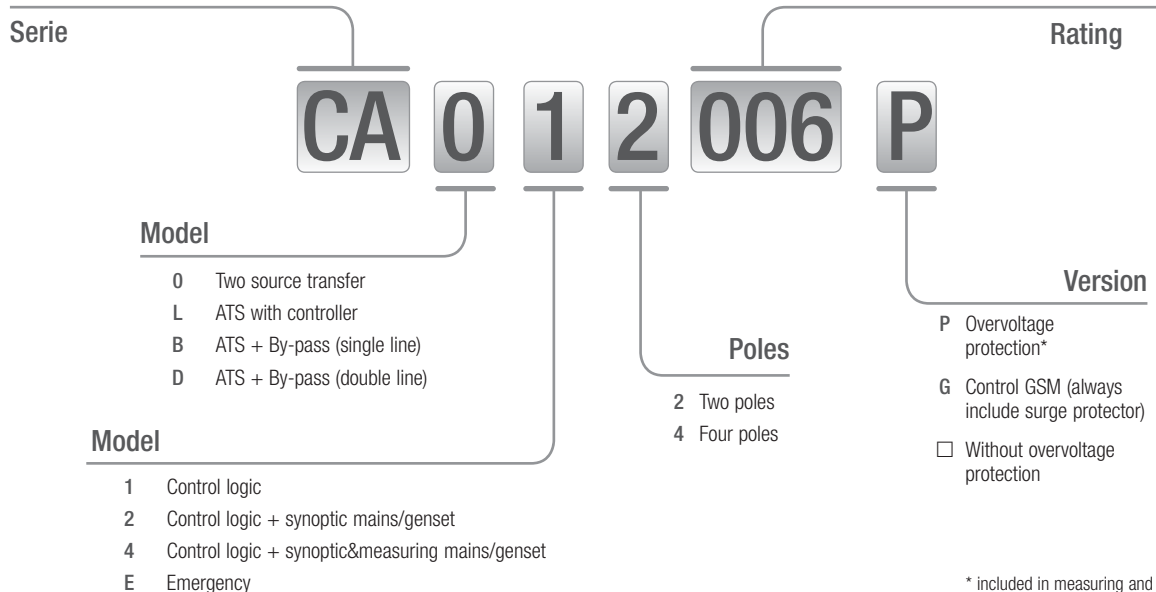

## Y SERIES

- **Complete set:**
  - Components integrated on metal steel enclosure IP66 with embedded cable entry plate with neoprene seal.
  - Foamed-in polyurethane gasket guarantees watertightness for years.
  - Fixing brackets, fastened with screws from the outside, can be placed horizontally or vertically.
  - Epoxy polyester texturised powder coating colour grey RAL-7035.
  - Enclosure resistance to impact IK10.
- 3mm standard double bar lock. Wide variety of lock transformations available.
- Ventilation and thermal solutions available.
- Door opening 110° and earthing continuity with enclosure.
- Terminal connection with flexible cable up to 35mm<sup>2</sup> on transfers ratings up to 125A.
- Cable lug connection from 160A up to 250A.



### → *Functionality*

Simple "Plug&Play" transfer. Extensive range covering multiple function possibilities such as measuring, gsm, emergency, by-pass,...

### → *Installation*

Wall mounting panels with large cable entries and straightforward terminal connection.

### → *Switching*

Well established changeover switching technology with excellent electrical and mechanical endurance characteristics.

### → *Control*

User friendly logic control easy to program. Signalling leds inform about control relays status or screen display with controller.

### → *Reliability*

Local operation guarantees safe disconnection and transfer operation under all circumstances.

# ATS System diagram



- ❶ Initial status. Mains supply OK.
- ❷ Phase control relay RF1/controller detects failure on Mains supply.
- ❸ Volt free output contact changes status commanding Generator start.
- ❹ Phase control relay RF2/controller detects Genset output is OK.
- ❺ Timer TM1 delays transfer to Genset.
- ❻ Transfer to Genset is operated.
- ❼ Failure on Mains supply is over.
- ❽ Timer TM2 counts return time before retransfer.
- ❾ Retransfer is operated and output contact returns to initial status commanding Genset stop.

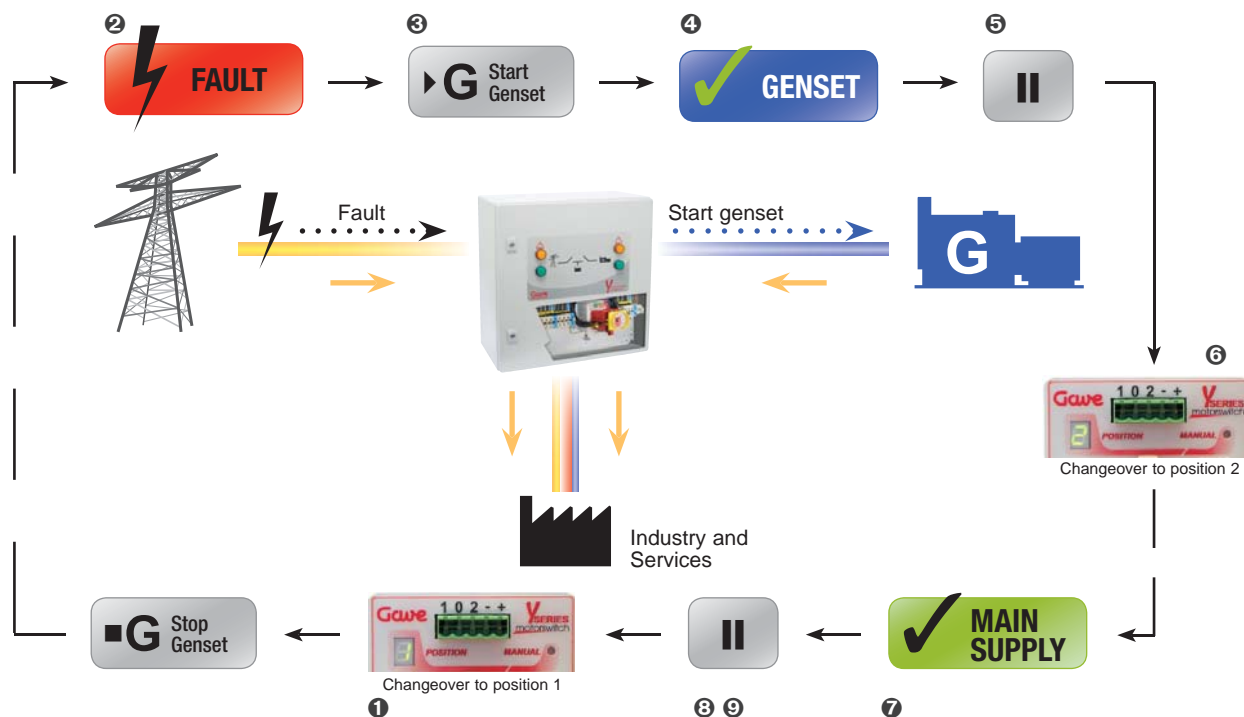

## ATS with signalling



### Function

Automatic transfers 02 are the best choice on those applications where we need constant indication on supply status. A user friendly large size synoptic using easy to understand symbols and high luminosity led pilot lights guarantee that source condition is under control.

### Specific characteristics

- Local emergency/maintenance manual operation.
- User friendly configuration.
- Easy cable access "plug&play".
- Operation counter.
- Control logic protected against lightning surge overvoltage (optional).

### References

Description	A	2 poles	4 poles	Logic overvoltage protected	
				2 poles	4 poles
ATS synoptic	40	CA022004	CA024004	CA022004P	CA024004P
ATS synoptic	63	CA022006	CA024006	CA022006P	CA024006P
ATS synoptic	100	CA022010	CA024010	CA022010P	CA024010P
ATS synoptic	125	CA022012	CA024012	CA022012P	CA024012P
ATS synoptic	160	-	CA024016	-	CA024016P
ATS synoptic	200	-	CA024020	-	CA024020P
ATS synoptic	250	-	CA024025	-	CA024025P

### Dimensions

40-125A

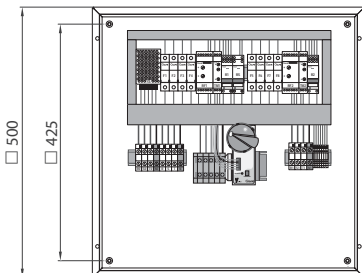

160-250A

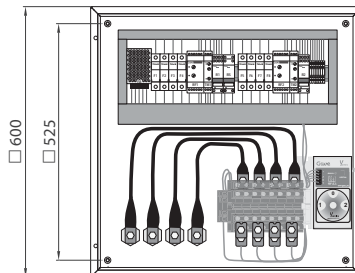



# ATS with measuring

## Function

Automatic transfer switches integrating measuring functionality are specially adequate on those installations where electricity distribution needs to be monitored and energy management wants to be implemented independently from the supply source.

## Specific characteristics

- Multimeasure on transfer output.
- High accuracy 0,2% (TRMS measurement).
- Large cabling space.
- Backlit high luminosity LCD display with easy readout.
- User friendly synoptic panel informs on transfer status.
- Control logic and measurement protected against lightning overvoltage.



- Backlit LCD display.
- Direct access button for currents (instantaneous and max. values), current THD and set up wiring correction.
- Direct access button for voltages and frequencies.
- Direct access button for active, reactive and apparent power (instantaneous and max. values) and power factor.
- Direct access button for energies.

## References

Description	A	2 poles	4 poles
ATS + Measuring	63	CA042006	CA044006
ATS + Measuring	100	CA042010	CA044010
ATS + Measuring	125	CA042012	CA044012
ATS + Measuring	160		CA044016
ATS + Measuring	200		CA044020
ATS + Measuring	250		CA044025

## Dimensions

63-125A

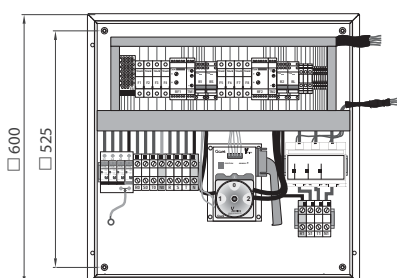

160-250A

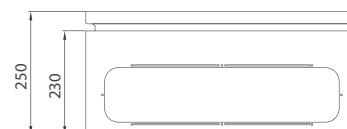
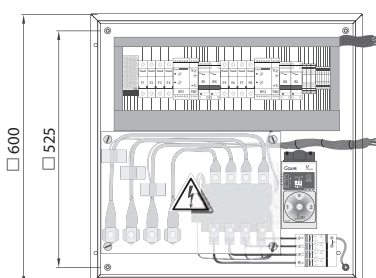

## ATS with emergency function

### Function

Automatic transfers with emergency function are specially adequate on industry and public buildings where a quick access to emergency supply stop is required. An internal battery system guarantees transfer system supply autonomy assuring automatic operation and effective emergency external stop.

### Specific characteristics

- Emergency stop mushroom with trigger action according to EN418
- Power supply secured with built-in battery system.
- Power supply with battery charger.
- Synoptic signalling battery supplied.
- Control logic and measurement protected against lightning surge overvoltage.



### Emergency stop



- ❶ Emergency stop. Push latching mushroom with trigger action. Changeover switches to position 0. Blue pilot lights on indicating changeover switch on position 0 and red pilot lights on indicating emergency stop.
- ❷ Turn mushroom to release. Automatic transfer command return to logic control.

### References

Description	A	2 poles	4 poles
ATS + emergency	40	CA0E2004	CA0E4004
ATS + emergency	63	CA0E2006	CA0E4006
ATS + emergency	100	CA0E2010	CA0E4010
ATS + emergency	125	CA0E2012	CA0E4012
ATS + emergency	160	-	CA0E4016
ATS + emergency	200	-	CA0E4020
ATS + emergency	250	-	CA0E4025

### Dimensions

#### 40-125A

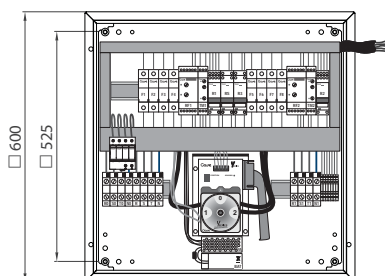

#### 160-250A

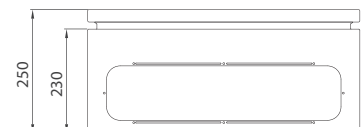
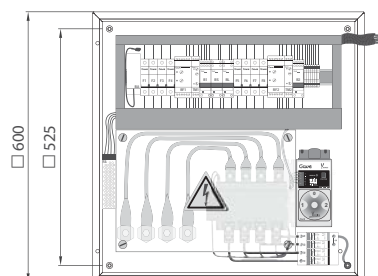

# ATS with controller



## Function

CTL range of automatic transfer switches are specially adequate on those installations with confined spaces where we need a compact solution that does not jeopardise cabling and commissioning conditions.

## Specific characteristics

- Multiparameter controller (voltage, frequency, time delays and transfer sequence).
- Network typology selection.
- Dual power supply.
- Frontal display for parameters readout and programming.
- Controller automatic and manual override mode.
- Led status indications.
- Local manual operation on emergency or maintenance/ test operations.

## ATS Controller

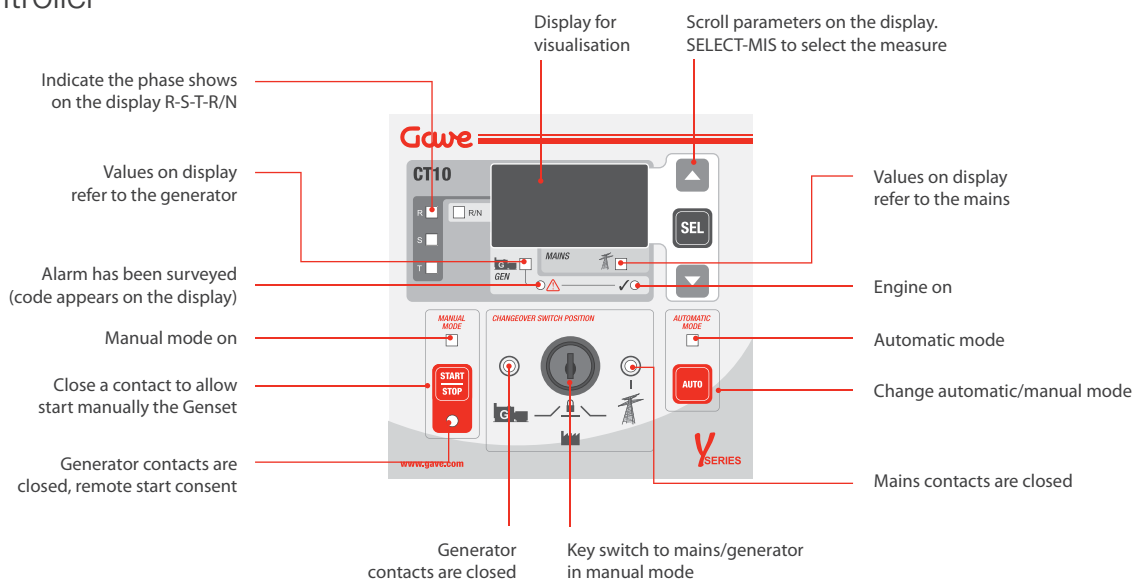

## Mounting options



### Surge protection device

ATS controller protected against lightning by Class II modular SPD with end of life indication and replacement modules. Protection in common and differential mode compatible with TT and TN networks.



### GSM Control

Smart distance monitoring sends messages on transfer status and events information. GSM controller is preprogrammed but local reset button permits reprogramming all messages upon application needs and particular country language.

Led indication informs about GSM network availability.

Unit thermal control with alert messages and safeguard operation.

Local manual test mode available.

## References

Description	A	Standard	With SPD	With GSM
ATS with controller	63	CTL14006	CTL14006P	CTL14006G
ATS with controller	100	CTL14010	CTL14010P	CTL14010G
ATS with controller	125	CTL14012	-	-
ATS with controller	160	CTL14016	CTL14016P	CTL14016G
ATS with controller	200	CTL14020	CTL14020P	CTL14020G
ATS with controller	250	CTL14025	CTL14025P	CTL14025G

## Dimensions

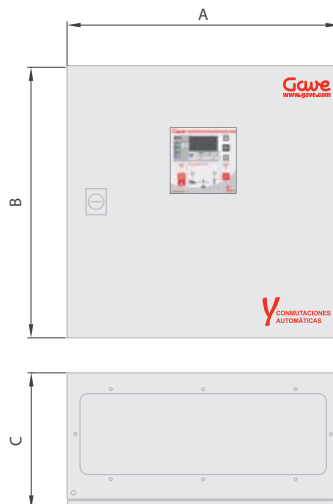

Size / Type	Standard	With SPD	With GSM
63-125A	A	400	500
	B	400	500
	C	200	230
160-250A	A	500	600
	B	500	600
	C	230	250



## ATS with By-pass

Automatic transfer switches with integrated by-pass on load manual changeover are the most compact solution available in the market, involving significant savings on the installation project and meaning the most cost effective solution.

### Specific characteristics

- Plenty of cabling space.
- Easy commissioning - Plug&play.
- Large external synoptic.
- CT10 controller with key manual selection.
- Dual power supply.

### Single line

On those installations where we might change controller programming or plan regular maintenance procedures we should integrate a by-pass isolation switch. This configuration provides supply continuity on the load side while permitting testing operations on the ATS under safety conditions.

### Double line

Critical power installations should be able to offer supply continuity also under the event of mains power failure while the ATS is isolated on maintenance/testing purposes. A double line by-pass configuration with an additional manual transfer switch is the solution.

## Integrated solutions

Conventional approach on by-pass systems requires one ATS changeover plus two additional changeovers with complex interlock systems in order to get a single line by-pass system. Furthermore in many designs we should add a switch disconnecter to guarantee safe isolation. Double-line systems would add an extra changeover switch.

*Minimise initial equipment cost with less components, reduce installation time and increase system reliability are the goals achieved by Gawe engineering team with its innovative integrative approach.*

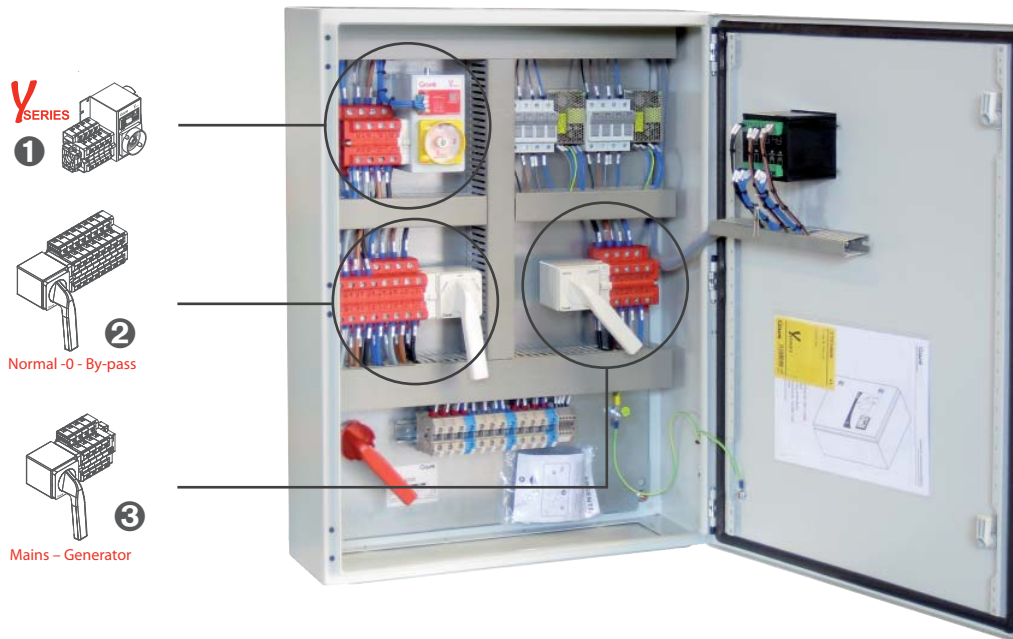

By-pass single line

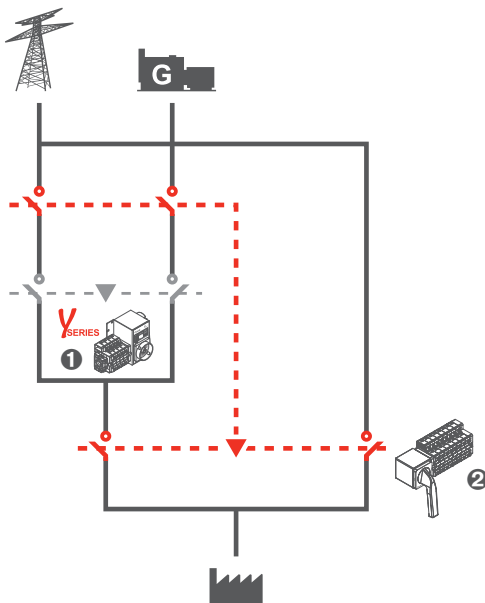

By-pass double line

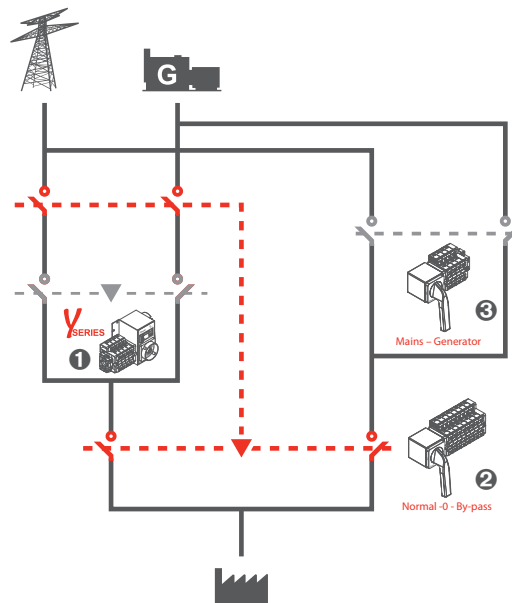



## References single line

Description	A	Standard	With SPD	With GSM
ATS + By-pass single line	63	CTB14006	CTB14006P	CTB14006G
ATS + By-pass single line	100	CTB14010	CTB14010P	CTB14010G
ATS + By-pass single line	125	CTB14012	CTB14012P	CTB14012G
ATS + By-pass single line	160	CTB14016	CTB14016P	Consult
ATS + By-pass single line	200	CTB14020	CTB14020P	Consult
ATS + By-pass single line	250	CTB14025	CTB14025P	Consult

## References double line

Description	A	Standard	With SPD	With GSM
ATS + By-pass double line	63	CTD14006	CTD14006P	CTD14006G
ATS + By-pass double line	100	CTD14010	CTD14010P	CTD14010G
ATS + By-pass double line	125	CTD14012	CTD14012P	CTD14012G
ATS + By-pass double line	160	CTD14016	CTD14016P	Consult
ATS + By-pass double line	200	CTD14020	CTD14020P	Consult
ATS + By-pass double line	250	CTD14025	CTD14025P	Consult

## Dimensions

### By-pass single line

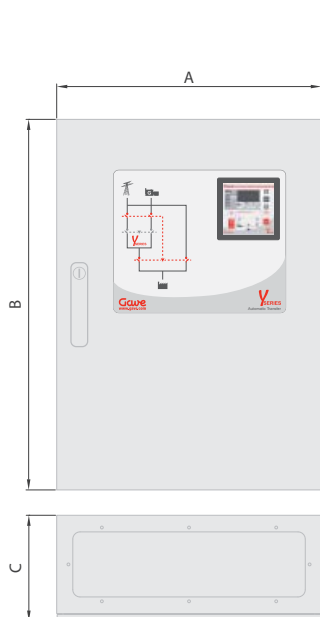

### By-pass double line

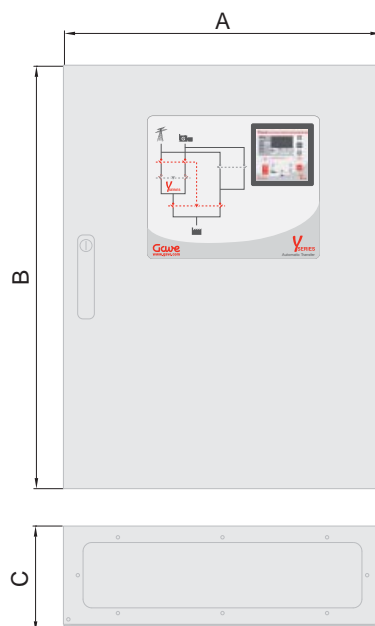

		Size / Type	Standard	With SPD	With GSM
By-Pass Single line	63-100A	A	500	500	-
		B	700	700	-
		C	200	200	-
	160-250A	A	600	600	-
		B	800	800	-
		C	200	200	-
By-Pass Double line	63-100A	A	600	600	-
		B	800	800	-
		C	200	200	-
	160-250A	A	800	800	-
		B	1000	1000	-
		C	250	250	-

## Other products

### ¿Do you need expert support?

We are assisting a large number of specific demands covering multiple varieties on automatic transfer needs ranging from simple adaptations to complex system design.

### ¿Do you have special needs?

#### **SP/TPN transfers**

Changeover between two power supplies one single phase (two poles) and the other three phases (three or four poles).

#### **Transfers with specific supplies**

Automatic transfers with specific power supplies for control logic including direct voltage and battery systems.

#### **Transfers with controllers**

Automatic transfers with specific controllers integrating specific functions as genset start, control, monitoring, ...

#### **Hazardous environments**

Automatic transfers with particular requirements for hazardous environments. Increased IP protection, aluminium enclosures, unit thermal management, ...

#### **Transfers with Measuring and communication**

Automatic transfer integrating communication on



the output measuring functionality (RS485 JBUS/ MODBUS; RS485 PROFIBUS/DP; Ethernet).

#### **Multisource transfers**

Using specific controllers or combining two source controllers we can build transfer systems that operate multisource changeover switches establishing sequence priorities.

#### **Hybrid multisource transfers**

Multisource transfers that can combine AC and DC on load switching.

#### **Power batteries transfers**

Monitoring battery load levels we can transfer between two battery banks guaranteeing supply continuity by using motorised changeover switches with overlapping position.

#### **Phase selection transfers**

On installations where single phase failure is frequent we can add an automatic/manual phase selector in the transfer unit that will switch to any available line.

**gave electro, s.l.**

P. O. Box 12 08430 La Roca del Vallès (Barcelona) SPAIN

[www.gave.com](http://www.gave.com) - [export@gave.com](mailto:export@gave.com)

Phone +34 93 842 48 87

Fax +34 93 842 27 55