

Terminal Protection to IP20



Dims: to DIN 43880  
W. 17.5mm

- Compact 17.5mm DIN rail housing
- Microprocessor based
- True R.M.S. monitoring measuring phase to phase (3-wire) or phase to neutral (4-wire) voltages
- Selectable nominal voltages to suit most popular 3-wire or 4-wire supply voltages
- Monitors own supply, detects phase asymmetry and if fixed Under or Over voltage trip levels are exceeded
- Detects incorrect phase sequence, phase loss and neutral loss<sup>1</sup>
- Adjustment for phase asymmetry/unbalance
- Adjustment for Restart delay
- Adjustment for Time delay
- DPDT relay output 5A
- Green LED indication for supply status
- Red LED indication for relay status



<sup>1</sup> Only when 4-wire monitoring selected

### FUNCTION DIAGRAM

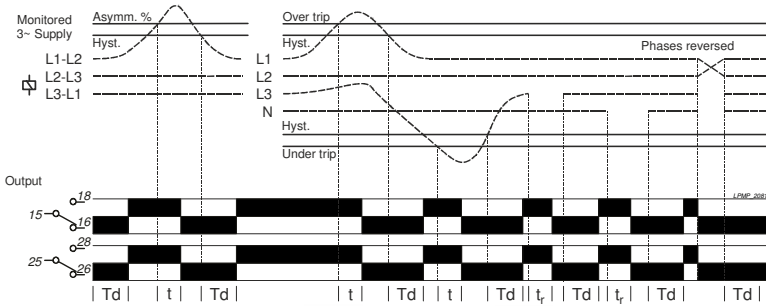

### TECHNICAL SPECIFICATION

Supply/monitoring voltage Un (L1, L2, L3, (N)):	3-wire monitoring <b>3-Wire</b>	4-wire monitoring <b>4-Wire</b>		
380, 400, 415V AC	220, 230, 240V AC			
Frequency range:	48 – 63Hz			
Supply variation:	243- 540V AC (L-L)			
Overvoltage category:	III (IEC 60664)			
Rated impulse withstand voltage:	4kV (1.2/50µs) IEC 60664			
Power consumption (max.):	2.5VA			
Monitoring mode:	Asymmetry, Under and Over voltage			
Trip levels:	Under [2]: Fixed ± 2% see below Under: Fixed – 90% of Un Over: Fixed – 110% of Un Asymmetry: 2 – 8%			
Measuring ranges:	Nominal (Un)	Under [2]	Under	Over
3-wire (L-L)	380V	243V	342V	418V
	400V	256V	360V	440V
	415V	265V	374V	457V
4-wire (L-N)	220V	140V	198V	242V
	230V	147V	207V	253V
	240V	153V	216V	264V
Hysteresis:	≈ 2% of trip level (factory set)			
Setting accuracy:	± 3%			
Repeat accuracy:	± 0.5% at constant conditions			
Immunity from micro power cuts:	<50ms			
Response time (t <sub>r</sub> ):	≈ 50ms			
Time delay (t <sub>d</sub> ):	0.2 – 10s (± 5%)			
Restart/Power on delay (Td):	1s – 500s			
Reset time:	50 – 100ms			
Power on indication:	Green LED			
Relay status indication:	Red LED			
Ambient temperature:	-20 to +60°C			
Relative humidity:	+95% max.			
Output (15, 16, 18 / 25, 26, 28):	DPDT relay			
Output rating:	AC1	250V 5A (1250VA)		
	AC15	250V 2A		
	DC1	25V 5A (125W)		
Electrical life:	≥ 150,000 ops at rated load			
Dielectric voltage:	2kV AC (rms) IEC 60947-1			
Rated impulse withstand voltage:	4kV (1.2/50µs) IEC 60664			
Housing:	Grey flame retardant UL94			
Weight:	90g			
Mounting option:	On to 35mm symmetric DIN rail to BS EN 60715 or direct surface mounting via 2 x M3.5 or 4BA screws using the black clips provided on the rear of the unit.			
Terminal conductor size	≤ 2.5mm <sup>2</sup> solid or stranded			
Terminal screw:	M2.5			
Tightening torque:	0.4Nm (3.5Lb-In) Max.			
Approvals:	Conforms to IEC, CE, UKCA, and RoHS Compliance, <b>UL LISTED</b> IND. CONT. EQ. E111187, EMC: Immunity: EN 61000-6-2 Emissions: EN 61000-6-4			
Note: "L>L" has the same meaning as "phase to phase" and "L>N", the same as "phase to neutral" "Asymmetry" formula $\text{Asymmetry} = \frac{\text{Maximum deviation from } V_{\text{ave}}}{V_{\text{ave}}} \times 100\%$ where $V_{\text{ave}}$ is the average of the three phases [ANSI/NEMA MG 1-2001] Note that "Phase asymmetry" can also be referred to as "Phase unbalance"				

### INSTALLATION AND SETTING



Installation work must be carried out by qualified personnel.

- BEFORE INSTALLATION, ISOLATE THE SUPPLY.
- Connect the unit as required. The Connection Diagram below shows a typical installation, whereby the supply to a load is being monitored by the Phase monitoring relay. If a fault should occur (i.e. fuse blowing), the relay will de-energise and assuming control of the external Contactor, de-energise the Contactor as well.
- Only connect the Neutral if available and 4-wire monitoring is required.

#### Applying power.

- Set the "Nominal (Un) ③ voltage selector to match that of the voltage being monitored.
- Set the "Asymmetry %" ⑥ adjustment to maximum.
- Set the "Delay (t) ⑤" and "Restart delay" ④ adjustments to minimum.
- Apply power and the green "Power supply" ① LED will illuminate. The red LED ② will illuminate and relay energise after the short delay period (Td).
- Refer to the troubleshooting table if the unit fails to operate correctly.

#### Setting the unit (with power applied).

- Assuming all phases are perfectly balanced it should be possible to set the "Asymmetry (%)" adjustment to minimum which will ensure that it will detect the smallest of changes in the phase voltages. However, if large changes in phase voltages are likely, then the "Asymmetry (%)" setting should be increased.
- The formula used for calculating phase asymmetry is shown on the right at the bottom of the Technical Specification.
- Set the "Delay (t)" and "Restart delay" as required. (Note that the delay "t" is only effective should any phases exceed the set trip point. However, if the supply drops below the 2<sup>nd</sup> under voltage trip level, any set time delay is automatically cancelled and the relay de-energises immediately).

#### Troubleshooting.

The table below shows the status of the unit during a particular fault condition.

Supply fault	Green LED ①	Red LED ②	Relay
Phase or neutral missing	LED's flash alternately	Off	De-energised
Phase or neutral restored (during restart timing)	On	Flashing (x2)	De-energised for delay (Td)
Phases reversed (no delay)	Flashing	Off	De-energised
Under or Over voltage condition (during timing)	On	Flashing	Energised for delay (t)
Under or Over voltage condition (after timing)	On	Off	De-energised
Voltage returned from Under/Over volt. (during restart timing)	On	Flashing (x2)	De-energised for delay (Td)
Phase asymmetry trip point exceeded (during timing)	On	Flashing	Energised for delay (t)
Phase asymmetry trip point exceeded (after timing)	On	Off	De-energised
Phase asymmetry below trip point (during restart timing)	On	Flashing (x2)	De-energised for delay (Td)
Phases < fixed under trip level [2]	On	Off	De-energised

### CONNECTION DIAGRAM

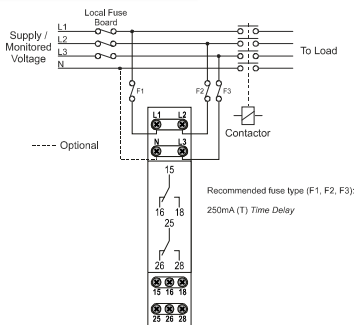

### SETTING DETAILS

1. Power supply status (Green) LED
2. Relay output / Timing status (Red) LED
3. "Nominal (Un)" voltage selector
4. "Restart delay" adjustment
5. "Delay (t)" adjustment
6. "Asymmetry %" trip adjustment

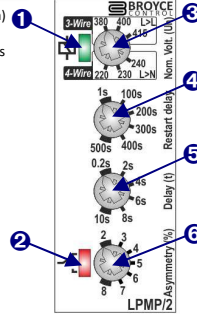

### DIMENSIONS

